

Current part is item (14) on diagram. Available at www.oshkoshequipment.com

(1) SMR Code	(2) Federal Stock Number	DESCRIPTION	UNIT of meas	Qty inc. in Unit	30-day DS maint allowance			30-day GS maint allowance			1-yr alw per 100 equip cnt- gcy	Depot maint alw per 100 equip	Illustration	
					(a) 1-20	(b) 21-50	(c) 51-100	(a) 1-20	(b) 21-50	(c) 51-100			(a) Figure No.	(b) Item No.
		Reference Number & Mfr. Code												
		Usable On Code												
PAHZZ	5310-959-4679	WASHER, LOCK: HOUSING MTG MS35340-45 (96906)	EA	6				*	*	*	*	*	3	11
PAHZZ	2805-888-3396	PLATE, LOCK: HOUSING MTG (U/W ALUMINUM HOUSING ONLY) 11610040 (19207)	EA	2				*	*	*	*	*	3	12
PAHZZ	2815-918-0595	SEAL, PLAIN, INCASED: CRANKCASE, OIL, REAR 10951177 (19207)	EA	1				*	*	*	*	*	3	13
PAHZZ	2815-860-0562	GASKET: HOUSING MTG 10889749 (19207)	EA	1				*	*	*	*	*	3	14
PAFZZ	5315-010-3736	PIN, STRAIGHT, HEADLESS: LOCATING 103736 (21450)	EA	2	*	*	*	*	*	*	*	*	3	15
PAHZZ	5310-177-9340	WASHER, FLAT: CRANKSHAFT JV1136 (76680)	EA	1				*	*	*	*	*	3	16
PAHZZ	2815-081-3416	SEAL, PLAIN, ENCASED: FRONT OIL 10912514 (19207)	EA	1				*	*	*	*	*	3	17
PBFZZ	2815-918-4202	PULLEY AND DAMPER ASSEMBLY: CRANKSHAFT 10935278 (19207)	EA	1	*	*	*	*	*	*	*	*	3	18
PADZZ	5305-543-2419	SCREW, CAP, HEXAGON HEAD: DAMPER MTG MS90728-61 (96906)	EA	8						*	*	*	3	19
PADZZ	2815-909-3781	LOCKPLATE, NUT: DAMPER MTG 10951333 (19207)	EA	4						*	*	*	3	20
PADZZ	2590-999-5332	RING, STIFFENER: DAMPER 10951332 (19207)	EA	1						*	*	*	3	21
PADZZ	2815-955-5505	DAMPER, VIBRATION: CRANKSHAFT 10935267 (19207)	EA	1						*	*	*	3	22
PADZZ	2815-871-2827	PULLEY, GROOVE: 10889886 (19207)	EA	1						*	*	*	3	23
PADZZ	5315-406-1544	PIN, STRAIGHT, HEADLESS: PULLEY 10898729 (19207)	EA	1						*	*	*	3	24
XADZZ		PULLEY, GROOVE: CRANKSHAFT 10889863 (19207)	EA	1						*	*	*	3	25
PADZZ	5315-498-7029	PIN, STRAIGHT, HEADLESS: PULLEY 10898728 (19207)	EA	1						*	*	*	3	26
PAFZZ	5310-850-3998	WASHER, FLAT: PULLEY TO CARANKSHAFT, MTG 10889748 (19207)	EA	1	*	*	*	*	*	*	*	*	3	27
PAFZZ	5306-454-8625	BOLT, EXTERNALLY RELIEVED BODY: PULLY TO CRANKSHAFT, MTG 10889931 (19207)	EA	1	*	*	*	*	*	*	*	*	3	28
PAFZZ	2805-039-7236	PLATE, LOCK: BOLT RETAINING 8713857 (19207)	EA	1	*	*	*	*	*	*	*	*	3	29
PAFZZ	5310-959-4675	WASHER, LOCK: PLATE MTG MS35340-46 (96906)	EA	2	*	*	*	*	*	*	*	*	3	30
PAFZZ	5305-269-3209	SCREW, CAP, HEXAGON HEAD: PLATE MTG MS90725-58 (96906)	EA	2	*	*	*	*	*	*	*	*	3	31
-HZZ		PLUG: PULLEY 11610011 (19207)		1									3	32
PAFZZ	2815-860-0561	DEFLECTOR, DIRT AND LIQUID: CRANKSHAFT 10889746 (19207)	EA	1	*	*	*	*	*	*	*	*	3	33
XAFZZ		GEAR, HELICAL: CRANKSHAFT 10889820 (19207)	EA	1	SEE SET 2815-074-8914								3	34
XAHHZ		CAP ASSEMBLY, BEARING: FRONT MAIN 10889884 (19207)		1									3	35
PAHZZ	5315-010-3736	PIN, STRAIGHT, HEADLESS: BEARING CAP 103736 (21450)	EA	1				*	*	*	*	*	3	15



Current part is item (14) on diagram. Available at www.oshkoshequipment.com

Current part is item (14) on diagram. Available at www.oshkoshequipment.com

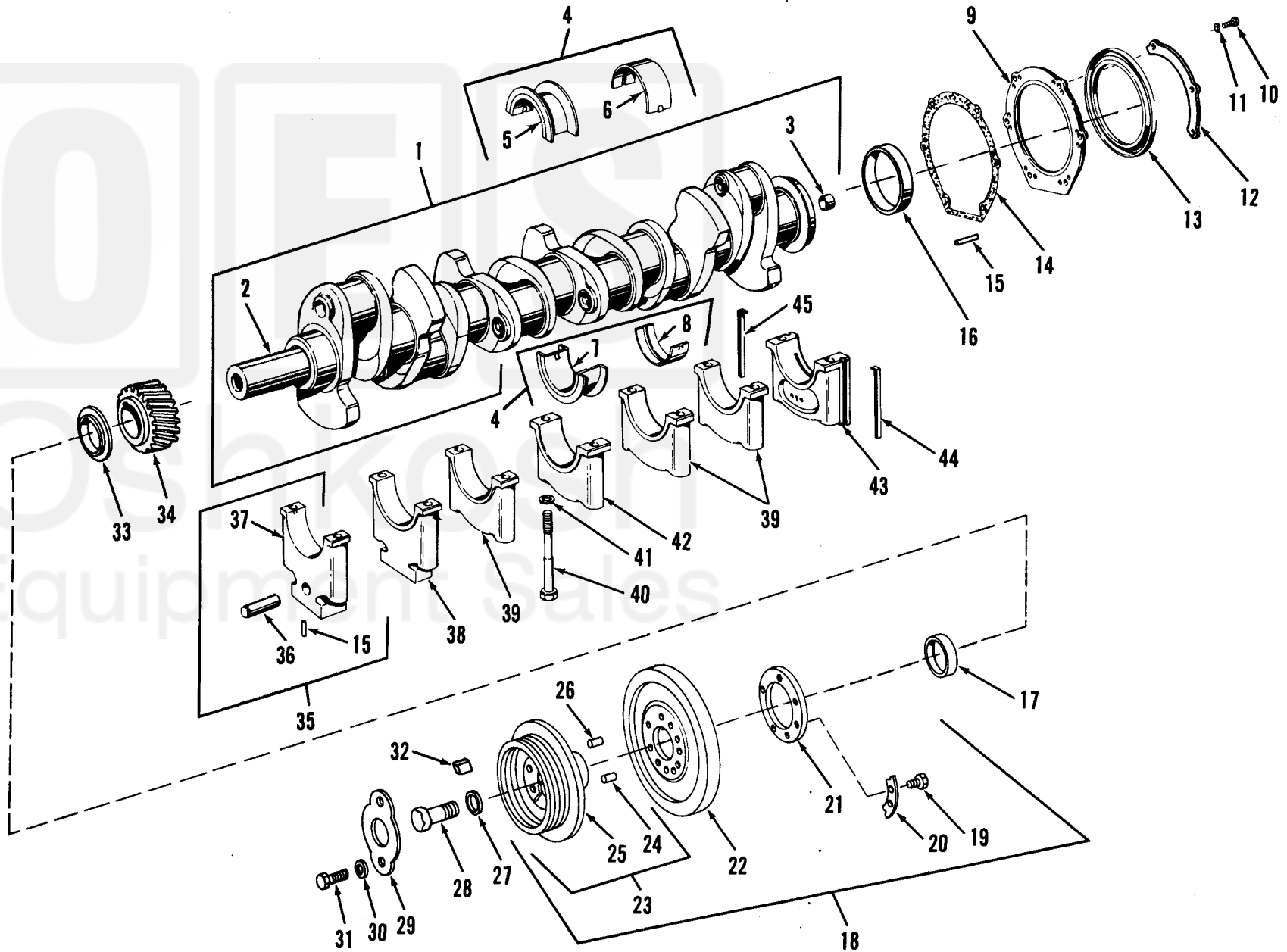

Figure 3. Crankshaft, Main Bearings and Associated Parts.

TA010709

Current part is item (14) on diagram. Available at www.oshkoshequipment.com